

Group standard

VW 60330

Issue 2013-12

Class. No.: 69606

Descriptors: crimp connection, electrical connection, crimp, contact, connector, solderless connection

Crimp Connections

Solderless Electrical Connections

Previous issues

VW 60330: 1993-01, 2008-07, 2009-12

Changes

The following changes have been made to VW 60330: 2009-12:

- Section 1 "Scope" revised;
- Section 2 "Symbols and abbreviations" added;
- Section 4.2.2 "Stripping" revised;
- Section 4.2.3 "Conductor end" revised;
- Section 4.3.4 "Dimensions of the conductor crimp" revised;
- Section 4.3.7.3 "Asymmetrical O-shaped SWS crimp (wrap crimp)" renamed and revised;
- Figure 30 changed;
- Section 5.2 "Crimping devices" revised;
- Section 5.3 "Crimp force monitoring" revised;
- Figure 31 changed;
- Section 5.1.1 "Test scope for alternative crimping tools" revised;
- Table B.1 and Table B.2 adapted.

Always use the latest version of this standard.

This electronically generated standard is authentic and valid without signature.

The English translation is believed to be accurate. In case of discrepancies, the German version is alone authoritative and controlling.

Numerical notation acc. to ISO/IEC Directives, Part 2.

Page 1 of 29

Technical responsibility		The Standards department	
EEKK/2	Ingo Eckhardt	Tel.: +49 5361 9 76439	EKDV/3 Tim Hofmann
I/EE-23	Dr. Hans Bauer	Tel.: +49 841 89 43405	EKDV
			Tel.: +49 5361 9 27995
			Maik Gummert

All rights reserved. No part of this document may be provided to third parties or reproduced without the prior consent of one of the Volkswagen Group's Standards departments.

© Volkswagen Aktiengesellschaft

VWNORM-2012-05q

Contents

	Page
1	Scope 3
2	Symbols and abbreviations 3
3	Terms 3
3.1	General 3
3.2	Designations for the crimp connection 4
3.2.1	Open crimp barrel 4
3.2.2	Closed crimp barrel 5
3.2.3	Conductor crimp 5
3.2.4	Insulation crimp 5
3.2.5	Single-wire seal crimp (SWS crimp) 5
3.2.6	Connection A 5
3.2.7	Connection B 5
4	Requirements 5
4.1	General requirements 5
4.2	Cable 5
4.2.1	General 5
4.2.2	Stripping 6
4.2.3	Conductor end 7
4.3	Requirements for the crimped contact element 8
4.3.1	Contact elements 8
4.3.2	Damage 8
4.3.3	Bending and twisting 8
4.3.4	Dimensions of the conductor crimp 8
4.3.5	Dimensions of the conductor crimp 13
4.3.6	Insulation crimp 14
4.3.7	Single-wire seal crimp (SWS crimp) 16
4.4	Cut-off tab 18
5	Producing the crimp connection 18
5.1	Tools 19
5.1.1	Test scope for alternative crimping tools 19
5.1.2	Release recommendation 19
5.2	Crimping devices 20
5.2.1	General 20
5.2.2	Crimp height 20
5.2.3	Conductor pull-out strength 20
5.3	Crimp force monitoring 20
5.4	Non-destructive testing 21
5.4.1	Crimp width 21
5.4.2	Crimp height 21
5.5	Destructive testing 22
5.5.1	Conductor pull-out strength 22
5.5.2	Microsection 22
5.5.3	Insulation crimp testing 23
5.5.4	Examples for not-OK (NOK) microsections 23
6	Applicable documents 25
7	Bibliography 25
Appendix A	Release recommendation form 26
Appendix B	Quality assurance 27
B.1	Quality matrix for release testing 27
B.2	Quality matrix for testing during production 29

1 Scope 本标准规定了评估使用压接筒和由软铜制成的多股、细绞合和超细绞合导线生产的无焊电气压接连接的定义、要求和试验标准

This standard specifies the definitions, requirements, and test criteria for evaluating solderless electrical crimp connections that are produced using crimp barrels and multi-stranded, fine-stranded, and ultra-fine stranded conductors made of flexible copper.

This standard also specifies the requirements for producing, testing, and evaluating crimp connections. In individual cases, the standard part drawings of the contacts and cable lugs provide detailed crimp specifications. 本标准还规定了压接连接的生产、测试和评估要求。在个别情况下，触点和电缆接线片的标准零件图提供了无尾压接规范

In addition to this, the contact manufacturers supply processing specifications containing additional information that must also be taken into consideration. 除此之外，联系制造商提供的加工规范中还必须考虑其他信息

Specifications in the respective standard part drawing take precedence. 以各标准零件图中的规范为准

This standard is not applicable to solid cables, aluminum conductors, or flat ribbon lines.

本标准不适用于实心电缆、铝导线或扁平带状线

2 Symbols and abbreviations

$A_{\text{conductor}}$	Nominal conductor cross section
BMG	Build sample approval
CFE	Distance between crimp barrel ends
Ch	Crimp height
C_{mk}	Machine capability index (process capability index)
C_{pk}	Process capability index
Cw	Crimp width
Cwm	Measurable crimp width
FSTR	First-sample test report
Fa	Barrel end clearance
Fh	Flash height
Fw	Flash width
IEV	International Electrotechnical Vocabulary
La	Supporting height
PG	Test group
P_{pk}	Process performance index
S	Contact material thickness
SMT	Slow motion test
SWS	Single-wire seal
Sb	Base thickness
α_w	Supporting angle

3 Terms

3.1 General

The terms and definitions in this standard are specified in IEC 581 [1].

For the designations, see figure 1 and figure 2.

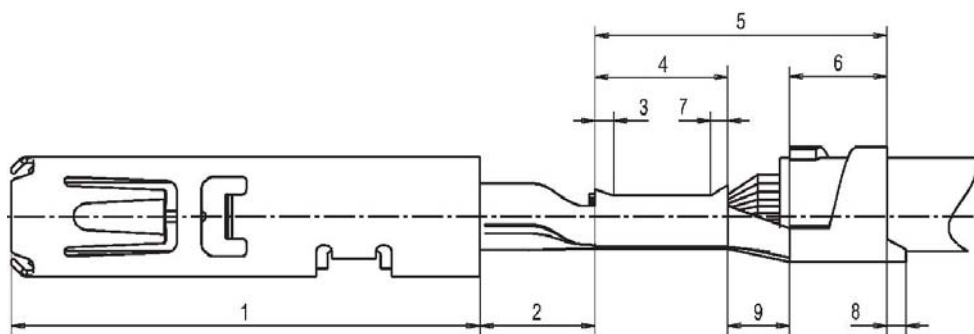

Legend

- 1 Contact range
- 2 Connection A
- 3 Front bellmouth
- 4 Conductor crimp
- 5 Crimp connection
- 6 Insulation crimp
- 7 Rear bellmouth
- 8 Cut-off tab
- 9 Connection B

Figure 1 – Crimp connection, terms – side view

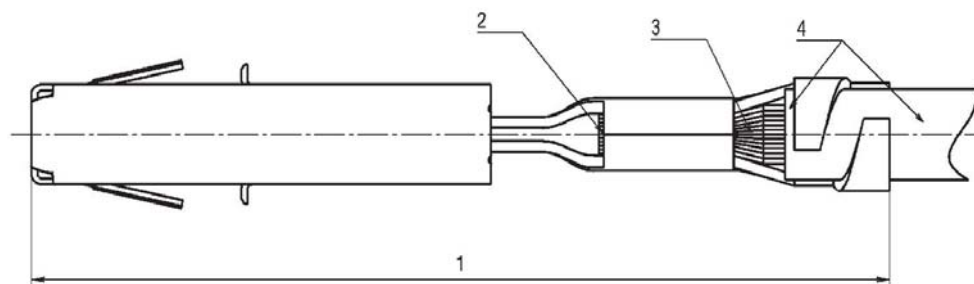

Legend

- 1 Contact element
- 2 Conductor end
- 3 Conductor
- 4 Insulation

Figure 2 – Crimp connection, terms – top view

3.2 Designations for the crimp connection

3.2.1 Open crimp barrel

Open crimp barrels are conductor crimps, insulation crimps, or SWS crimps with a U-shaped, V-shaped, or pre-shaped opening. Open crimp barrels are customary in punched contact elements. The crimping operation simultaneously closes the open crimp barrel while separating the contact element from the transport strip.

开口压接筒是指具有U形、V形或预成型开口的导体压接、绝缘压接或SWS压接。开压接筒通常用于冲压接触元件。压接操作同时关闭打开的压接筒，同时从传送带上分离接触元件。

3.2.2 Closed crimp barrel

Conductor crimps, insulation crimps, or SWS crimps with closed contours have closed crimp barrels. They are customary in tubular cable lugs. Closed crimp barrels are usually conductor crimps. SWS crimps or insulation crimps in the form of closed crimp barrels require significant resources and are therefore seldom implemented.

3.2.3 Conductor crimp

A conductor crimp is a connection between the contact element and the stranded conductor. The conductor crimp must ensure the permanent electrical connection between the contact element and the stranded wire.

3.2.4 Insulation crimp

An insulation crimp is a connection between the contact element and the cable at the outer diameter of the insulation. The insulation crimp is designed to absorb mechanical loads and vibrations to prevent them from affecting the conductor crimp. For the design types of the insulation crimp, see [section 4.3.6](#).

3.2.5 Single-wire seal crimp (SWS crimp)

An SWS crimp is a connection between the contact element and the SWS by means of compression deformation. The SWS crimp must ensure permanent fit of the single-wire seal on the contact element.

For the design types of the single-wire seal crimp, see [section 4.3.7.2](#) and [section 4.3.7.3](#).

3.2.6 Connection A

Connection A is the transition area between the contact range and the conductor crimp.

3.2.7 Connection B

Connection B is the transition area between the conductor crimp and the insulation crimp.

4 Requirements

4.1 General requirements

Crimp connections must be implemented as per the drawing specifications in their version currently in effect. The contact part manufacturer must specify the component-specific crimp dimensions (crimp height, crimp width, etc.), which are documented in the standard part drawing. These specified crimp dimensions must be adhered to exactly. Depending on the conductor cross sections and contact elements to be processed, the wear part profiles or crimper and anvil profiles must be properly matched.

压接连接必须按照当前有效版本的图纸规范进行。接触件制造商必须规定部件特定的压接尺寸。(卷边高度、卷边宽度等), 记录在标准零件图中。必须严格遵守这些特定的压接尺寸。根据要加工的导体横截面和接触元件, 磨损件轮廓或压接器和砧形必须正确匹配。

4.2 Cable

4.2.1 General

Only copper stranded cables that have bare or surface-treated strands and have been released by Volkswagen must be used; VW 60306-1 applies.

只能使用裸股或表面处理股并由大众汽车释放的铜股电缆; 大众60306-1适用。

The electrical conductor must not be dip-tinned or soldered.

Cable material whose properties have been adversely affected must not be used.

After 2 years of storage at the latest, proof must be provided that the cable material can still be used. The cable material must continue to adhere to the requirements in VW 60306-1 and the corresponding standard part drawing.

4.2.2 Stripping

Special tools must be used for stripping. Damages to the strands, i.e., scoring, notching, etc., particularly with the stripping knife, must not occur during the teach-in process for the crimp force monitoring system. The length of insulation to be stripped must be defined by the cable manufacturer under consideration of the applicable regulations.

Protruding strands are not permissible (see figure 3).

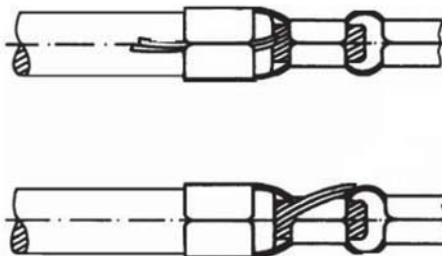

Figure 3 – Protruding strands

If the stripped cable will not be processed immediately, the stripped ends must be protected from fraying (e.g., by means of an insulation barrel).

Fraying of the strands is not permissible (see figure 4).

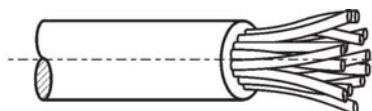

Figure 4 – Frayed stranded wire

Unclean cutting of the insulation, damage to the insulation, or the presence of insulation residues on the stripped portion of the conductor is not permissible (see figure 5).

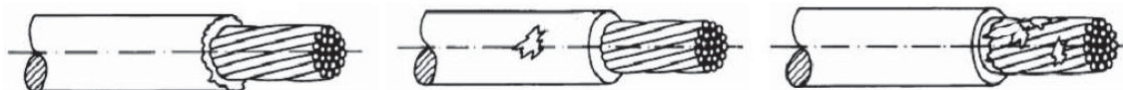

Figure 5 – Defective insulation

Strands must not be over-twisted, in order to prevent the strands from being cut or damaged during the crimping operation (see figure 6).



Figure 6 – Over-twisted conductor end

4.2.3 Conductor end

The conductor end (see figure 7) terminates at a point not before the conductor crimp end or, depending on the cross section of the conductor, extends beyond it (see table 1).

Table 1 – Permissible conductor projection

Nominal conductor cross section $A_{\text{conductor}}$ in mm ²	Conductor projection in mm
$A_{\text{conductor}} < 4$	≤1,0
$4 \leq A_{\text{conductor}} < 6$	≤1,5
$6 \leq A_{\text{conductor}} < 25$	≤2,5
$A_{\text{conductor}} \geq 25$	≤3,5

The plugging, latching, or bolting function of the contact element must not be impaired by the projecting end of the conductor.

For cable lugs, the conductor end also must not extend into the bolt-on surface.

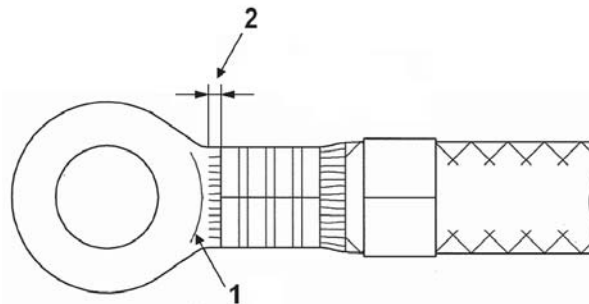

Legend

- 1 Extended outer diameter
- 2 Conductor projection

Figure 7 – Maximum protrusion of the conductor end

For plug contacts intended for use with collective seals, projecting strands are not permissible (see figure 8).

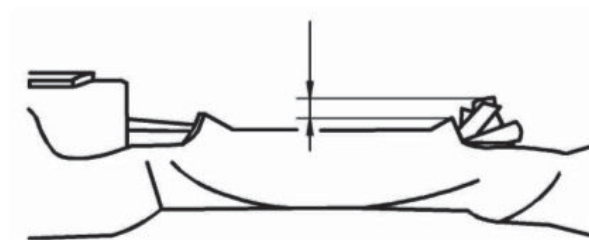

Figure 8 – Projecting strands

The insulation end must be visible in the window between the wire crimp barrel and insulation crimp barrel. No cable insulation must be caught in the conductor crimp.

4.3 Requirements for the crimped contact element

4.3.1 Contact elements

The contact elements used must conform to the requirements and specifications of the standard part drawing. There must not be any mechanical damage or twisting/bending of the transport strip or contact elements. 使用的接触元件必须符合标准零件图的要求和规范。运输带或接触元件不得有任何机械损伤或扭曲/弯曲

Contact material whose properties have been adversely affected must not be used. 不得使用性能受到不利影响的接触材料。

After 2 years of storage at the latest, proof must be provided that the contact material can still be used. The contact material must still adhere to the requirements in VW 75174 and the corresponding standard part drawing. 最迟在储存2年后，必须提供证据证明接触材料仍然可以使用。接触材料必须仍然符合VW 75174和相应标准零件图的要求。

4.3.2 Damage

The contact range (see figure 1) and the locking pins must not be damaged or deformed after the crimping operation. Deformations of the contact element as a result of crimping in its contact range are not permissible.

4.3.3 Bending and twisting

If the standard part drawing does not contain any specifications, the following requirements apply:

- The lateral bending of the longitudinal axis in the crimping zone must not exceed 3° towards either side (see figure 9).
- Bending of the longitudinal axis in the crimping zone must not exceed 5° upward or downward. Twisting of the crimping zone relative to the contact body must not exceed 5° (see figure 10).

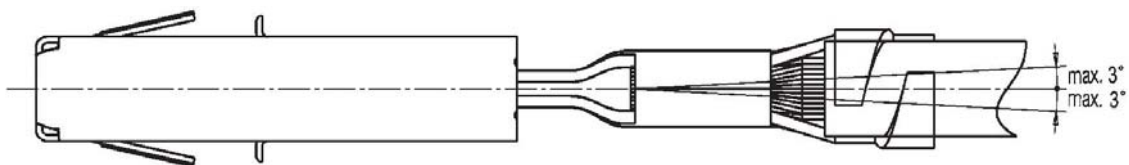

Figure 9 – Lateral bending

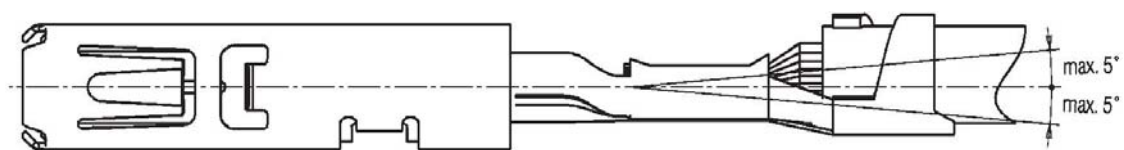
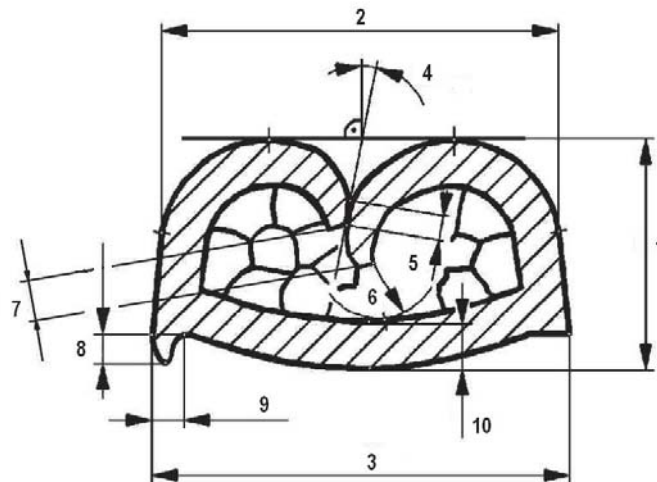

Figure 10 – Bending of the longitudinal axis of the contact element

4.3.4 Dimensions of the conductor crimp

4.3.4.1 General

For the dimensions of the conductor crimp, see figure 11.



Legend

- | | |
|----|--|
| 1 | Crimp height (Ch) |
| 2 | Crimp width (Cw) |
| 3 | Measurable crimp width (Cwm) |
| 4 | Supporting angle (α_w) |
| 5 | Supporting height (La) |
| 6 | Barrel end clearance (Fa) |
| 7 | Distance between crimp face ends (CFE) |
| 8 | Flash height (Fh) |
| 9 | Flash width (Fw) |
| 10 | Base thickness (Sb) |

Figure 11 – Dimensions of the conductor crimp

The thickness of the contact material (s) in the crimp area must be taken from the standard part drawing. Limits are specified for the indicated crimp dimensions. Any deviating values specified in standard part drawings are binding.

Uneven rolling-in of the two crimp barrel ends is permissible, provided that the requirements for the supporting length, supporting angle, and distance between crimp face ends are adhered to.

The specified crimp dimensions must be tested as per the quality assurance matrix specifications (see [appendix B](#)) and documented by the wiring harness manufacturer.

The evaluation of crimp results must take into account process-dependent fluctuations.

4.3.4.2 Crimp height (Ch)

The crimp height must be measurable using a nondestructive method. 必须使用非破坏性方法测量卷边高度

The crimp height is an adjustable (not tool-related) dimension of the crimp connection. 压接高度是压接连接的可调（与工具无关）尺寸。

The crimp height is specified by the contact element manufacturer and is documented on the standard part drawing of the corresponding contact element. 压接高度由接触元件制造商规定，并记录在相应接触元件的标准零件图上。

If crimp height tolerances are not specified on the standard part drawing of the contact element, the general tolerances for the crimp height as per [table 2](#) apply, depending on the conductor cross section.

如果接触元件的标准零件图上未规定压接高度公差，则表2中的压接高度一般公差适用，具体取决于导线横截面。

Table 2 – General tolerances for the crimp height with respect to the conductor cross section

Nominal conductor cross section A_{con-} ductor in mm^2	Tolerance in mm
$0,13 < A_{conductor} \leq 0,5$	$\pm 0,03$
$0,5 < A_{conductor} \leq 2,5$	$\pm 0,05$
$A_{conductor} > 2,5$	$\pm 0,10$

For the crimp height measurement, see [section 5.4.2](#).

For repeat accuracy requirements, see [section 5.2](#).

4.3.4.3 Crimp width (Cw) 压接宽度与工具有关，即压接接头的尺寸不可调整。

The crimp width is a tool-related, i.e., non-adjustable dimension of the crimp connection.

The crimp width is specified by the contact element manufacturer and is documented along with the corresponding tolerance in the standard part drawing of the corresponding contact element.

压接宽度由接触元件制造商规定，并在相应接触元件的标准零件图中记录相应公差。

4.3.4.4 Measurable crimp width (Cwm)

The measurable crimp width must be measurable using a nondestructive method.

The width of the crimp at the crimp base can be determined with a dial gage, for example. It is specified by the contact element manufacturer, and must be documented with corresponding tolerance in the standard part drawing of the corresponding contact element.

4.3.4.5 Supporting angle (α_w)

The supporting angle (see [figure 12](#)) can only be determined using a microsection.

The supporting angle must not deviate more than 30° from the vertical ($\alpha_w \leq 30^\circ$).

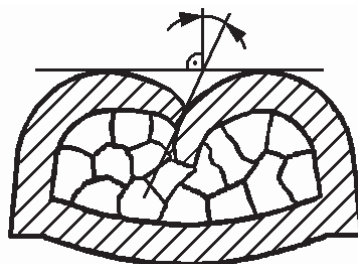

Figure 12 – Supporting angle

4.3.4.6 Supporting height (La)

The supporting height (see [figure 13](#)) can only be determined using a microsection.

The crimp barrel must be closed along its entire length between the bellmouths. The rolled-in crimp barrel ends touch and support each other. As a minimum requirement, the supporting height of the crimp face ends, depending on the conductor cross section, must be equal to the proportion of contact material thickness indicated in [table 3](#).

Table 3 – Supporting height with respect to the conductor cross section

Nominal conductor cross section $A_{\text{conductor}}$ in mm^2	Supporting height
$A_{\text{conductor}} < 1,0$	$\geq 0,5 \times S$
$1,0 \leq A_{\text{conductor}} < 6,0$	$\geq 0,7 \times S$
$A_{\text{conductor}} \geq 6,0$	$\geq 1,0 \times S$

The specifications of the release drawing are always binding (see section 1).

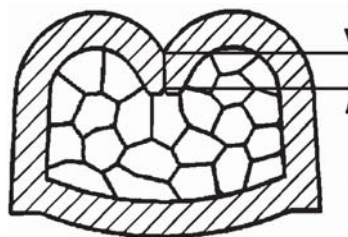

Figure 13 – Supporting height

4.3.4.7 Barrel end clearance (Fa)

The barrel end clearance (see figure 14) can only be determined using a microsection.

None of the crimp face ends must abut the inner wall of the crimp barrel.

The barrel end clearance is:

$$Fa \geq 0,1 \times S$$



Figure 14 – Symmetry and rolling-in depth

4.3.4.8 Distance between crimp face ends (CFE)

The distance between the crimp face ends can only be determined using a microsection.

The distance between the opposite, rolled-in crimp face ends (see figure 15) is:

$$CFE = x_1 - x_2$$

$$CFE \leq 0,5 \times S$$

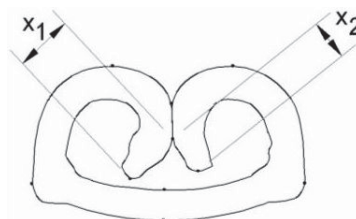

Figure 15 – Distance between the crimp face ends

4.3.4.9 Flash height (Fh)

The height of the flash is affected by the degree of wear of the crimping tool and the feed settings (see figure 16).

$$Fh \leq 1 \times S$$

4.3.4.10 Flash width (Fw)

The flash width (see figure 16) is:

$$Fw \leq 0,5 \times S$$

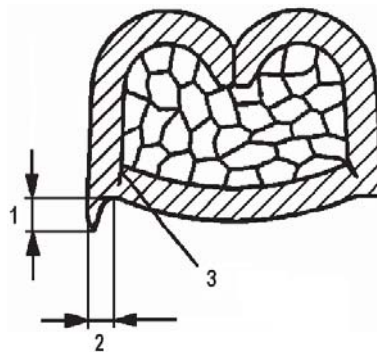

Legend

- 1 Flash height
- 2 Flash width
- 3 Crack (see section 4.3.5.2)

Figure 16 – Flash at crimp base

4.3.4.11 Base thickness (Sb)

The base thickness (see figure 17) can only be determined using a microsection.

The base thickness is:

$$Sb \geq 0,75 \times S$$

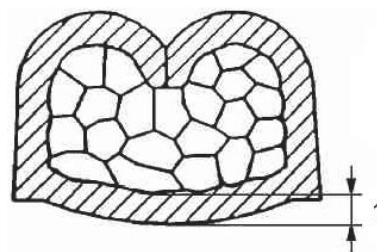

Legend

- 1 Base thickness

Figure 17 – Base thickness

4.3.4.12 Degree of compression

The degree of compression can only be determined using a microsection.

The manufacturer of the contact elements ensures that a good degree of compression is achieved when the specified crimp dimensions are adhered to. A good degree of compression is characterized by a completely filled crimp barrel, in which the strands in the wire crimp area are completely compressed in a honeycomb structure.

The degree of compression is the ratio of the conductor cross section enclosed in the crimp (crimped) to the uncrimped nominal conductor cross section:

$$\text{Degree of compression} = \frac{A_{\text{crimp}}}{A_{\text{conductor}}} \times 100\% \quad (1)$$

Legend

- A_{crimp} Cross section of the conductor enclosed in the crimp (measured as a polygonal chain in the microsection)
- $A_{\text{conductor}}$ Nominal conductor cross section

4.3.5 Dimensions of the conductor crimp

4.3.5.1 Crimp length

The conductor crimp must be closed along the entire length between the front and rear bellmouths (see figure 18). The rolled-in barrel ends support each other.

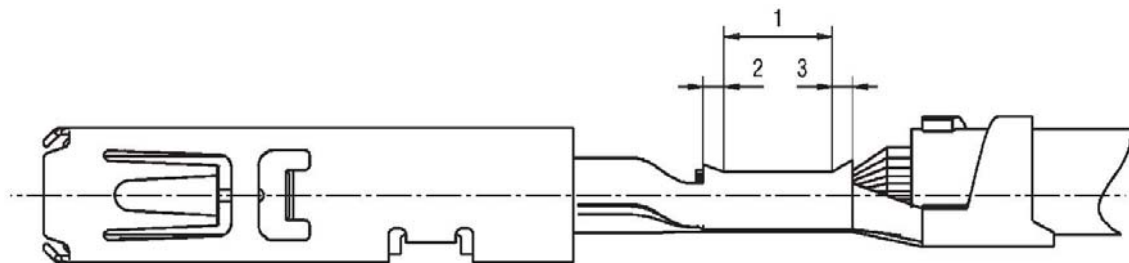

Legend

- 1 Crimp length
- 2 Front bellmouth
- 3 Rear bellmouth

Figure 18 – Crimp length and bellmouths

4.3.5.2 Cracks

Cracks (see figure 19) can be caused by various unfavorable circumstances, especially at the crimp base. Cracks must be distinguished from wrinkles that can occur at the inside of the rolled-in areas.

Cracks are not permissible.

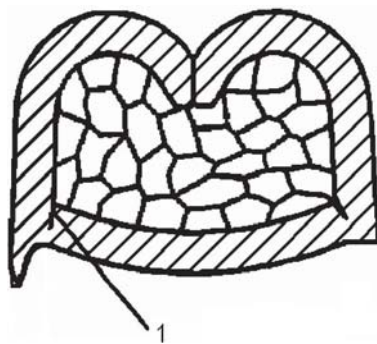

Legend

1 Crack

Figure 19 – Crack in the crimp base

4.3.5.3 Bellmouth

A bell-shaped runout (bellmouth) is required at the rear edge of the conductor crimp (towards the cable, see figure 18). This bellmouth is to prevent the strands from being notched or cut.

No bellmouth is prescribed at the front edge of the conductor crimp (towards the contact). A front bellmouth of equal or lesser size as the rear bellmouth is permissible.

4.3.6 Insulation crimp

The insulation crimp of the contact element must be designed as per the standard part drawing for a thin-walled or thick-walled insulated cable as per VW 60306-1.

The test for insulation holders in crimp connections as per DIN EN 60512-16-8 ("16-hour test") must be fulfilled. The BMG tests ensure that the 16-hour test mentioned above is fulfilled for use, as per the drawing specifications, of contacts, connectors, cables, and single-wire seals released by Volkswagen. This means that the 16-hour test by the cable manufacturer is not necessary under these circumstances.

4.3.6.1 Position deviations of the insulation crimp barrel ends

The crimp faces may be inclined within a range of 5° to the front and 3° to the rear (see figure 20).

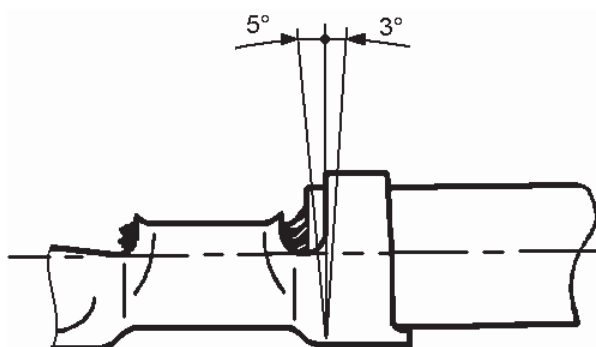

Figure 20 – Position deviations of the insulation crimp barrel ends

4.3.6.2 Insulation crimp, type A (F-crimp)

See figure 21 and figure 22.

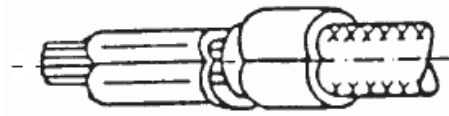
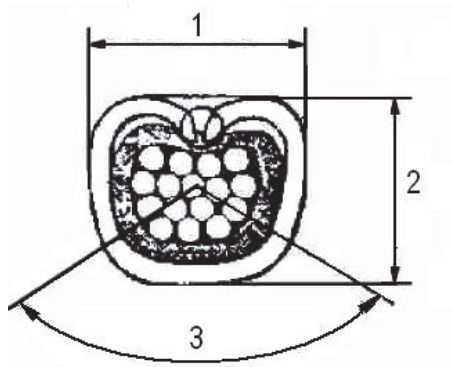

Figure 21 – Insulation crimp, type A



Legend

- 1 Crimp width
- 2 Crimp height
- 3 Wrap angle

Figure 22 – Dimensions of insulation crimp, type A

Compliance with the crimp width and crimp height dimensions specified in the standard part drawing is mandatory.

At least 1/3 of the cable circumference (120°) must be encompassed by the insulation crimp.

The crimp claws must enter into the insulation. The insulation may be punctured by the crimp claw, but this must not cause any damage to the strands.

4.3.6.3 Insulation crimp, type B (wrap crimp)

See figure 23 and figure 24.



Figure 23 – Insulation crimp, type B

At maximum cable diameter, the crimp barrel ends must overlap for a distance that is greater than or equal to their material thickness.

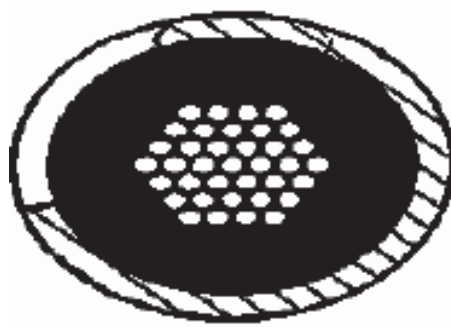

Figure 24 – Cross section of insulation crimp, type B

4.3.6.4 Insulation crimp, type C (overlap crimp)

See figure 25 and figure 26.

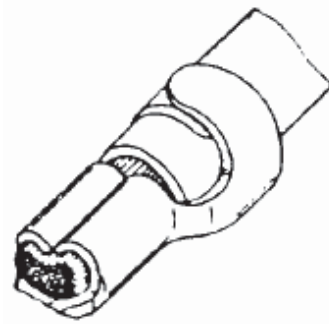

Figure 25 – Insulation crimp, type C

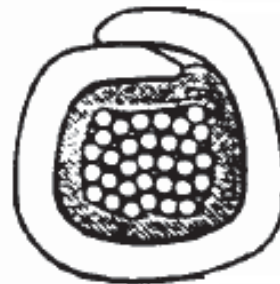

Figure 26 – Cross section of insulation crimp, type C

At least 2/3 of the cable circumference must be encompassed by the insulation crimp. The insulation envelopment must be closed (overlap). The insulation can be punctured by a crimp claw, but this must not cause any damage to the strands.

The test for insulation holders in crimp connections as per [DIN EN 60512-16-8](#) ("16-hour test") must be fulfilled.

4.3.7 Single-wire seal crimp (SWS crimp)

The crimp barrel ends must be rolled in to the extent that the single-wire seal is maintained reliably when the contact is fitted into the connector housing.

4.3.7.1 Position of the single-wire seal

The insulation crimp barrel must snugly wrap around the single-wire seal over the entire length. The single-wire seal must not be damaged or punctured by the crimp barrel ends. For the position of the single-wire seal as per the drawing specification, see figure 27.

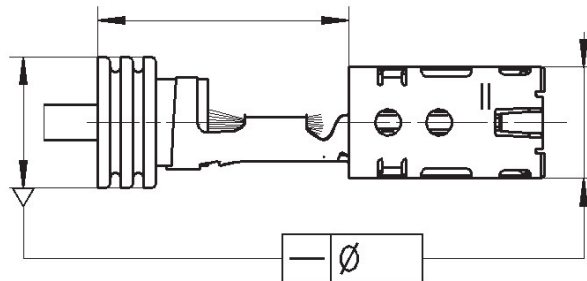

Figure 27 – Position of the single-wire seal in the crimp pattern of the standard part drawing

4.3.7.2 Symmetrical O-shaped SWS crimp (O-crimp)

The insulation crimp flaps wrap around the single-wire seal by a maximum of 360° (see figure 28). Overlapping of the crimp barrel ends is not permissible.

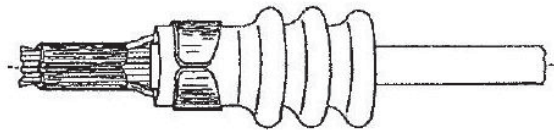

Figure 28 – Symmetrical O-shaped SWS crimp

4.3.7.3 Asymmetrical O-shaped SWS crimp (wrap crimp)

The insulation crimp flaps wrap around the single-wire seal by more than 360° (see figure 29).

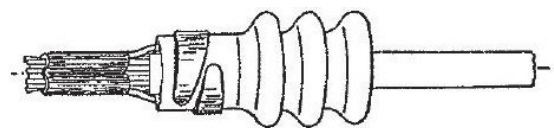
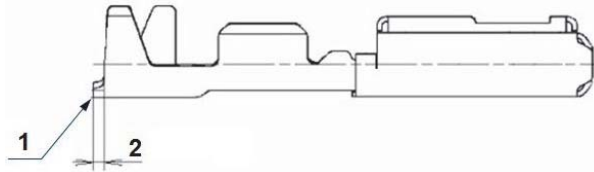

Figure 29 – Asymmetrical O-shaped SWS crimp

Cut-off tab and flash must not impair the fitting ability into the housing and the plug-in function of the contact.

4.4 Cut-off tab

The cut-off tab (see figure 30) is still visible at first and has a maximum length of up to one contact plate thickness ($\leq 0,5$ mm).



Legend

- 1 Flash
- 2 Cut-off tab

Figure 30 – Flash and cut-off tab

The permissible flash at the cut edge can be viewed for the various contact plate thicknesses S in table 4.

Table 4 – Flash with respect to plate thickness

Dimensions in mm	
Sheet thickness	Flash
$S \leq 0,4$	$\leq 0,05$
$0,4 < S \leq 0,8$	$\leq 0,10$
$S > 0,8$	$\leq 0,15$

The cut-off tab and flash must not impair the ability of the part to fit into the housing and the plug-in function of the contact in any way.

For plug contacts intended for use with collective seals, the length of the cut-off tab must not exceed 0,3 mm. The cut-off tab must not stick out.

Cut-off tab and flash must not damage the collective seal or single-wire seal.

The requirements also apply to removal and refitting of the contact element during subsequent rework.

5 Producing the crimp connection

The quality of a crimp connection can only be evaluated to a limited extent without destruction. Consequently, the required quality of the crimp connection and, thus, its functional capability, can only be achieved if:

- Fitting and suitable tools and wear parts are available;
- Fitting and suitable machines are available;
- Preventive maintenance of the indicated machines, tools, and wear parts is available;
- An expert operator is available;
- Effective and reliably applied process assurance based on crimp force monitoring is available.

The details for carrying out these requirements are defined in the quality assurance matrix (see appendix B).

5.1 Tools

The use of genuine crimping tools and inserts (wear parts) is required because the contact part manufacturer is responsible for the system. The respective standard part drawings of the contact part manufacturer, which are made available to the cable manufacturer via the Volkswagen systems, form the basis for this.

The contact part manufacturer has system responsibility for the contact part.

The cable manufacturer is responsible for the entire crimping process.

Justified deviations from these specifications require approval by the Design Engineering departments responsible for contact development and the Quality Assurance department of the vehicle manufacturer.

Genuine crimping tools and genuine wear parts are crimping tools and wear parts which have been confirmed by the crimping manufacturer for use in the respective crimp. In any event, the crimp dimension specifications of the contact drawing and this standard must be adhered to.

5.1.1 Test scope for alternative crimping tools

The contact manufacturer must check the crimps produced using the tool to be approved as per the specifications set forth in VW 75174:

- Incoming inspection (VW 75174, PG0);
- Dimensional check (VW 75174, PG1), including crimp dimensions in the microsection as per section 4.3.4;
- Wire pull-out strength (VW 75174, PG10);
- Crimp stability
 - Cables $\leq 1 \text{ mm}^2$: SMT as per VW 75174-2;
 - Cables $> 1 \text{ mm}^2$: Only thermal shock test as per VW 75174-2; however, with $T_o = 130 \text{ }^\circ\text{C}$ and number of cycles = 500.

5.1.2 Release recommendation

The suitability of alternative crimping tools and alternative wear parts must be confirmed by the contact manufacturer based on the specified tests by means of a release recommendation as per appendix A to the cable manufacturer.

The contact manufacturer is responsible for the specifications set forth in this release recommendation.

The cable manufacturer must document the release recommendation in the FSTR. The process responsibility remains with the cable manufacturer.

In addition, the cable manufacturer must send the release recommendation to the Design Engineering departments responsible for contact development and the QA department of the vehicle manufacturer.

5.2 Crimping devices

5.2.1 General

Crimping devices, which include both automatic cable manufacturing equipment and table presses (semi-automatic equipment), must be equipped with a device for continuous automatic monitoring of crimp quality.

Crimping devices must be equipped in such a way that a consistently high crimping quality is provided and faulty parts can be sorted out reliably.

The processing quality and the repeatability is evaluated based on the measured values of crimp height (see section 4.3.4.2) and conductor pull-out strength (see section 5.5.1). Crimp connections must be checked and evaluated statistically.

5.2.2 Crimp height

50 crimp connections must be crimped with nominal crimp height as per the release drawing (all cross section variants) and the crimp heights measured.

Crimp height requirement: $C_{mk} \geq 2,0$

5.2.3 Conductor pull-out strength

20 crimp connections must be crimped for every possible cross section, each with minimum and maximum crimp heights, respectively, as per the release drawing (all cross section variants).

Requirement: The average value less three times the standard deviation must be greater than the minimum conductor pull-out strength.

5.3 Crimp force monitoring

Crimp force monitoring involves a load-displacement measurement during the working stroke of the crimping tool: The load/displacement curve of an OK crimp moves within a target curve. This target curve is determined by a teach-in process:

- After every change in the tool settings;
- After every change of tool clamping/after every tool change;
- After every change of the contact roll.

To ensure the quality of the crimp connections produced, the teach-in crimp must be evaluated based on a microsection (see section 5.5.2.3) and the crimp dimensions that can be measured as a result (see section 4.3.4): In this context, a distinction is made between signal cables and load cables:

- Signal cables:
 - all cables $\leq 0,35 \text{ mm}^2$
 - all cables $> 0,35 \text{ mm}^2$ that are marked as signal cables in the wiring harness drawings
- Load cables:
 - all cables $\geq 0,5 \text{ mm}^2$

Signal cables $\leq 0,35 \text{ mm}^2$

A new microsection is required after every change to the contact roll and after every change to yard goods. Producing a microsection after changing the yard goods can be omitted if the

conductor type and manufacturer remain the same and if corresponding microsections are already available.

Signal cables of 0,5 mm²

A new microsection is required after every change to the contact roll and after every change to yard goods. Producing a microsection after changing the yard goods can be omitted if the conductor type and manufacturer remain the same and if corresponding microsections are already available. Signal cables of 0,5 mm² are marked as such in the wiring harness drawing.

Load cables

Microsection required after n crimps:

- $n = 1/6 \times \text{total service life}$, but at least once a year;
- $n = \text{at least every 30 000 crimps}$ for all contacts for which the tool service life is not yet known.

5.4 Non-destructive testing

5.4.1 Crimp width

The crimp width is a primarily tool-dependent dimension (section 5.1 applies). Suitable measuring means must be used.

5.4.2 Crimp height

The crimp height is a dimension that can primarily be affected during the crimping process and is crucial for the crimp resistance values and the stability of these values.

The crimp height measurement is taken in the center of the conductor crimp with suitable measurement means. An example with a special dial gage (crimp height dial gage) can be seen in figure 31.

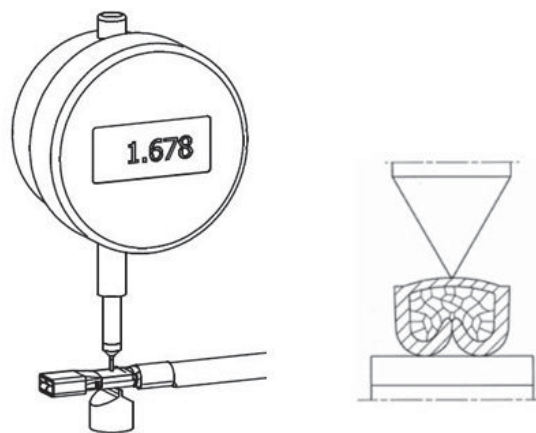

Figure 31 – Crimp height measurement using a special dial gage

5.5 Destructive testing

5.5.1 Conductor pull-out strength

The conductor pull-out force from the conductor crimp is measured as per VW 75174 as an accompanying manufacturing check and without insulation support (see table 5). The minimum values for the conductor pull-out strength for low-pressure contacts as per table 5 are required.

Table 5 – Minimum values for the conductor pull-out strength for low-pressure contacts

Cable nominal cross section in mm ² as per VW 60306-1	Contact size				
	0,63	1,2/1,5	2,8	4,8	9,5
0,13	50 N		—	—	—
0,17	50 N		—	—	—
0,22	50 N		—	—	—
0,35	50 N (75 N) ^{a)}				—
0,5	60 N (85 N) ^{a)}				—
0,75	85 N (105 N) ^{a)}				—
1,0	—	108 N (125 N) ^{a)}		140 N (162 N) ^{a)}	—
1,5	—	150 N (180 N) ^{a)}			—
2,5	—	—	200 N (235 N) ^{a)}		
4,0	—	—	—	310 N (325 N) ^{a)}	
6,0	—	—	—	(450 N) ^{a)}	450 N
10,0	—	—	—	—	500 N
16,0	—	—	—	—	1 500 N
25,0	—	—	—	—	1 900 N

a) If for production reasons, the conductor pull-out strength is measured with insulation crimp, the values in parentheses apply.

For requirements on the repeat accuracy of conductor pull-out strengths, see section 5.2.

5.5.2 Microsection

5.5.2.1 General

The microsection is located in the center of the conductor crimp, perpendicular to the longitudinal axis. The microsection plane must not be located within any of the transverse embossings in the wire crimp (see figure 32).

Ensure that the machining direction is opposite the direction of the crimp opening so that no forces occur during grinding that could open the crimp.

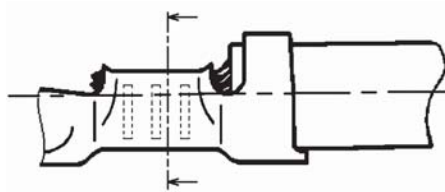

Figure 32 – Microsection plane

5.5.2.2 Metallographic sample preparation for BMG

In order to evaluate the crimp quality achieved with the crimping tool, microsections taken cross-wise through the conductor crimp must be prepared.

For tests that are not conducted during production, the part must preferably be cast in synthetic resin to prevent changes to the crimp when the microsection is prepared.

For a good evaluation capability, surface polishing and possibly surface etching are required after the separation of the crimp.

Evaluation criteria as specified in [section 5.5.2.3](#) and [section 5.5.1](#) apply.

5.5.2.3 Microsection preparation (conducted during production)

For production monitoring, the embedding of samples in synthetic resin is not required when producing microsections. Microsections are produced using suitable devices under consideration of the corresponding manufacturer specifications.

Unless otherwise specified, the quality assurance matrix applies (see [appendix B](#)).

The following specifications must be documented:

- Contact part number;
- Contact part supplier;
- Part number and manufacturer of the conductor yard goods;
- Microsections and, if applicable, measured values.

5.5.3 Insulation crimp testing

5.5.3.1 Insulation crimp testing for BMG

The insulation crimp is evaluated by testing as per [DIN EN 60512-16-8](#). The acceptance criterion is that the insulation must still be encompassed after the test is performed.

5.5.3.2 Insulation crimp testing (conducted during production)

Determination and documentation of the specified crimp widths and crimp heights using suitable measurement equipment. Unless otherwise specified, the quality assurance matrix applies (see [appendix B](#)).

5.5.4 Examples for not-OK (NOK) microsections

Some characteristics of NOK crimp connections are listed in [figure 33](#) to [figure 37](#).

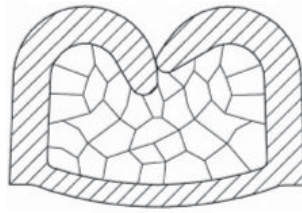

Figure 33 – The crimp tip is supported on the barrel end; the supporting height is insufficient

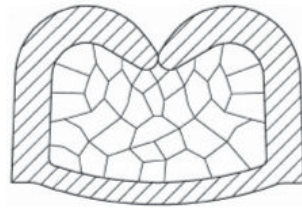

Figure 34 – Insufficient supporting height

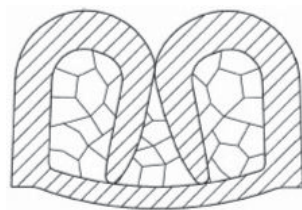

Figure 35 – Supporting height and barrel end clearance are insufficient

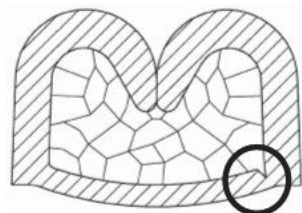

Figure 36 – Crack in the crimp base

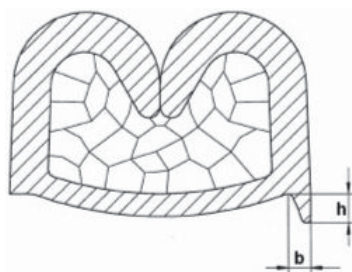

Figure 37 – Impermissible flash formation

6 Applicable documents

The following documents cited in this standard are necessary to its application.

Some of the cited documents are translations from the German original. The translations of German terms in such documents may differ from those used in this standard, resulting in terminological inconsistency.

Standards whose titles are given in German may be available only in German. Editions in other languages may be available from the institution issuing the standard.

VW 60306-1	Electric/Electronic Systems; Electric Wiring in Motor Vehicles; Part 1: Copper Cable; Single-Wire, Unshielded
VW 75147	Wiring Harnesses in Motor Vehicles; Quality Requirements for Products and Processes
VW 75174	Motor Vehicle Connectors; Test Specification
VW 75174-2	Vehicle Contacts, Slow Motion Tests
DIN EN 60512-16-8	Connectors for electronic equipment - Tests and measurements - Part 16-8: Mechanical tests on connections and terminations - Test 16h: Insulating grip effectiveness (crimped connections)

7 Bibliography

- [1] IEV 581 – Electromechanical Components for Electronic Equipment

Appendix A (informative) Release recommendation form

See figure A.1.

Release recommendation for alternative crimping tools VW 60330			
Originator:	Company: Location:	Phone:	Internal No.:
Contact No.:	Drawing date (design status):		
	Contact manufacturer:		
Designation:	Contact, manufacturing site/country:		
EC/ECE label (type approval no.):	DUNS number (Supplier no. if applicable):		
Crimping tool manufacturer			
Crimping tool (type, manufacturer no., etc.)			
Wear parts set manufacturer			
Wear parts set (type, manufacturer no., etc.)			
Motivation: <input type="checkbox"/> New crimping tool <input type="checkbox"/> New crimping tool manufacturer <input type="checkbox"/> Additional supplier <input type="checkbox"/> New wear parts <input type="checkbox"/> <input type="checkbox"/> New manufacturing site <input type="checkbox"/> New crimp dimensions <input type="checkbox"/> Other:			
Test		Test report no.	Date
TG 0	Incoming inspection		
TG 1	Dimensional check, including crimp dimensions in microsection according to VW 60330 Section 3.3.4		
TG 10	Conductor extraction values		
TG 31	Crimp stability Conductors up to and including 1 mm ² : SMT acc. to VW 75174-2 Conductors larger than 1 mm ² : Only temperature shock testing acc. to VW 75174-2, but with To=130° and number of cycles = 500.		
<p>According to above mentioned test reports, crimped contacts of standard part number N xxx xxx xx processed using the above-mentioned crimping tool and wear parts have been tested. The samples provided by the originator are in compliance with the requirements of test groups 0, 1, 10 and 31 of VW 75174.</p> <p>The test results prove that processing the contact N xxx xxx xx according to the specifications of the standard part drawing is possible using the above mentioned tool.</p> <p>The cable manufacturer is responsible for proof of processing capability and stability when using this tool as well as for repeatable manufacturing.</p>			
Notes			
Release recommendation is <input type="checkbox"/> granted <input type="checkbox"/> revoked			
Company	Phone	Date	Name head of central laboratory Signature

Figure A.1 – Release recommendation for alternative crimping tools

Appendix B (normative) Quality assurance

B.1 Quality matrix for release testing

See table B.1.

Table B.1 – Release testing

Section	Dimension/ characteristic/ attribute	BMG contact	FSTR contact	Release recommendation for alternative crimping tool	Machine capability (tool release, C_{mk})	Process capability (production release, C_{pk}/P_{pk})
Responsible party:		VW/Audi	Cable manufac- turer	Contact manufac- turer	Cable manufac- turer	Cable manufac- turer
Section 4.3.2	Damage to contact range/locking pins	e	e	e	e	e
Section 4.3.3	Contact – bending/twisting	e	e	e	e	e
Section 4.3.4.2	Crimp height (Ch)	m ^{a)}	m	m	m ^{a)}	m
Section 4.3.4.11	Base thickness (Sb) ^{b)}	m	m	m	e	e
Section 4.3.4.12	Compression ^{b)}	m	m	m	e	e
Section 4.3.4.3	Crimp width (Cw) ^{b)}	—	—	—	—	—
Section 4.3.4.4	Crimp width (Cwm) ^{b)}	m	m	m	m	m
Section 4.3.4.5	Supporting angle (α_w)	m	m	m	e	e
Section 4.3.4.6	Supporting height (La) ^{b)}	m	m	m	e	e
Section 4.3.4.7	Barrel end clearance (Fa) ^{b)}	m	m	m	e	e
Section 4.3.4.8	Distance between crimp barrel ends (CFE) ^{b)}	m	e	m	m	e
Section 4.3.4.9	Flash height (Fh) ^{b)}	m	m	m	e	e
Section 4.3.4.10	Flash width (Fw) ^{b)}	m	m	m	e	e
Section 4.3.5.3	Crimp bellmouths	e	e	e	e	e
Section 4.3.6	ISO crimp height	m	m	m	m	m
Section 4.3.6	ISO crimp width	m	m	m	m	m
Section 4.3.6	ISO crimp design	m	m	m	e	m
Section 4.3.7	Position of single-wire seal	m	m	m	e	e
Section 4.4	Cut-off tab/punching flash	e	e	e	e	e
Section 5.5.1	Conductor pull-out strength	m ^{a)}	m	m	m ^{a)}	m
Section 5.5.2	Microsection (for each cavity/cross sec- tion)	5	5	5	3	3
—	Processability (VW 60675 ^{c)})	m ^{d)}	—	m	1	—

Section	Dimension/ characteristic/ attribute	BMG contact	FSTR contact	Release recommendation for alternative crimping tool	Machine capability (tool release, C _{mk})	Process capability (production release, C _{pk} /P _{pk})
Responsible party:		VW/Audi	Cable manufac- turer	Contact manufac- turer	Cable manufac- turer	Cable manufac- turer
—	Monitoring capability (VW 60675 ^{c)})	m ^{d)}	m	m	m	m
<p>e evaluate m measure</p> <p>^{a)} Statistical evaluation to verify process reliability ^{c)} Draft is currently being prepared. ^{b)} Must be evaluated using a microsection ^{d)} for all variants of the release drawing</p>						

B.2 Quality matrix for testing during production

See table B.2.

Table B.2 – Testing during production

Section	Dimension/ characteristic/ attribute	FSTR for ca- ble: VW 75147	Verification of crimp quality as per VW 60330, section 5.3		Intervention in tool configuration (e.g., re- placement of wear parts)
			Signal cables ($\leq 0,35 \text{ mm}^2$ / $0,5 \text{ mm}^2$)	Non- signal cables	
To be carried out by		Cable manu- facturer	Cable manu- facturer	Cable manu- facturer	Cable manu- facturer
Section 4.3.2	Damage to contact range/locking pins	e	e	e	e
Section 4.3.3	Contact – bending/twisting	e	e	e	e
Section 4.3.4.2	Crimp height (Ch)	m	m	m	m
Section 4.3.4.11	Base thickness (Sb) ^{a)}	e	e	—	e
Section 4.3.4.12	Compression ^{a)}	e	—	—	—
Section 4.3.4.3	Crimp width (Cw) ^{a)}	—	—	—	—
Section 4.3.4.4	Crimp width (Cwm) ^{a)}	m	m	m	m
Section 4.3.4.5	Supporting angle (α_w)	e	e	—	e
Section 4.3.4.6	Supporting height (La) ^{a)}	e	e	—	e
Section 4.3.4.7	Barrel end clearance (Fa) ^{a)}	e	e	—	e
Section 4.3.4.8	Distance between crimp face ends (CFE) ^{a)}	—	e	—	e
Section 4.3.4.9	Flash height (Fh) ^{a)}	e	e	e	e
Section 4.3.4.10	Flash width (Fw) ^{a)}	e	e	e	e
Section 4.3.5.3	Crimp bellmouths	e	e	e	e
Section 4.3.6	ISO crimp height	m	m	m	m
Section 4.3.6	ISO crimp width	m	m	m	m
Section 4.3.6	ISO crimp design	e	e	e	e
Section 4.3.7	Position of single-wire seal	m	e	e	e
Section 4.4	Cut-off tab/punching flash	e	e	e	e
Section 5.5.1	Conductor pull-out strength	m	m	m	m
Section 5.5.2	Microsection (for each cavity/cross sec- tion)	3	1	—	1
—	Processability (VW 60675 ^{b)})	—	—	—	—
—	Monitoring capability (VW 60675 ^{b)})	—	—	—	—

e evaluate
m measure
a) Must be evaluated with a microsection
b) Draft is currently being prepared.