

Automotive Grade Coaxial Cable Performance Specification

SUMMARY OF CONTENTS

1	SCOPE	2
2	REFERENCES	2
3	GLOSSARY OF TERMS	2
4	GENERAL REQUIREMENTS	2
4.1	Cable Description	2
4.2	Restricted and Reportable Substances	3
4.3	Finished Cable, Dimensional Requirements	3
4.4	Cable Identification	3
4.5	Workmanship	3
4.6	Specification Sheets	4
4.7	Sample Preparation	4
4.8	Equipment	4
5	TEST REQUIREMENTS	5
5.1	Electrical Test Requirements	5
5.2	Mechanical and Environmental Test Requirements	7
	APPENDIX A	10
	Initial Certification Requirements	10
	Continuing Conformance Requirements	10
	APPENDIX B	11
	Default Tolerance Table	11
	APPENDIX C	12
	REVISIONS	12

The research data, analysis, conclusion, opinions and other contents of this document are solely the product of the authors. Neither the Society of Automotive Engineers, Inc. (SAE) nor the United States Council for Automotive Research (USCAR) certifies the compliance of any products with the requirements of nor makes any representations as to the accuracy of the contents of this document nor to its applicability for purpose. It is the sole responsibility of the user of this document to determine whether or not it is applicable for their purposes.

Copyright ©2006, USCAR ISBN: 0-7680-1711-4
All rights reserved.

Printed in U.S.A.

QUESTIONS REGARDING THIS DOCUMENT: (724) 772-8518 FAX (724) 776-3036
TO PLACE A DOCUMENT ORDER: (724) 776-4970 FAX (724) 776-0790

1 SCOPE:

This document specifies dimensional, functional and visual requirements for Automotive grade coaxial cable. This material will be designated AG for general-purpose automotive applications or AG LL for low loss applications. It is the responsibility of the user of this cable to verify the suitability of the selected product (based on dimensional, mechanical, electrical and environmental requirements) for its intended application. It is the responsibility of the supplier to retain and maintain records as evidence of compliance to the requirements detailed in this standard.

2 REFERENCES:

- SAE/USCAR-2
- SAE/USCAR-17
- SAE/USCAR-18
- SAE/USCAR-19
- MIL -C- 17G
- SAE J 1128
- ISO 6722
- IMDS STD101
- Global Automotive Declarable Substance list. See: www.gadsl.org
- **DaimlerChrysler:** CS-9003
- **Ford:** WSS-M99P9999-A1
- **General Motors:** GMW 3059

3 GLOSSARY OF TERMS:

- IMDS: International Material Data system
- ILRS: International List of Reportable Substances
- Automotive Grade 174 (AG174) similar to RG 174
- Automotive Grade 174 Low Loss (AG 174 LL)

4 GENERAL REQUIREMENTS:

4.1 Cable Description:

4.1.1 Temperature Class:

All AG and AG LL Coaxial cable covered by this specification shall be tested to and meet or exceed the requirements of the temperature class 1 as specified in SAE/USCAR-2. Coaxial cable capable of meeting higher temperature class requirements shall be identified by printing the temperature class on the jacket. (e.g., USCAR class 2) All cable covered in this specification shall be compatible with RF connectors as specified in SAE/USCAR-17, SAE/USCAR-18 and SAE/USCAR-19.

4.1.2 Operating Frequency:

The cable covered in this document will function in the Operating frequency range of DC to 4 GHz.

4.1.3 Fluid Resistance Requirements:

When this cable is to be used in an area that will be exposed to automotive fluids it must be tested to the Fluid compatibility test defined in SAE J 1128.

4.2 Restricted and Reportable Substances:

All materials used in Automotive Grade Coaxial Cable shall be free of intentionally added Lead, Cadmium, Hexavalent Chrome or Mercury and shall conform to the requirements of the OEM restricted material requirements. See: Section 2 References. The material contents of this cable shall be reported in the IMDS format.

4.3 Finished Cable, Dimensional Requirements:

Finished cable dimensions shall meet values listed in table 1. Measurement method shall be per MIL-C-17G 4.8.1~ 4.8.1.4.1

	AG174 and AG174LL
Outer Jacket diameter	.110" +/- .004"
Shield diameter	.088" max.
Dielectric diameter	0.060" +/- .003"
Inner conductor diameter	.0195"+/- .0015"

TABLE 1: Finished Cable Dimensions

4.4 Cable Identification:

- Cable identification shall include the appropriate Automotive Grade designation and temperature class as a minimum. Properties such as jacket color or other printing shall be agreed upon between customer and supplier.

4.5 Workmanship:

- Finished cable must meet the requirements shown in this standard over the entire length and at any point in a material lot.

4.6 Specification Sheets:

- Supplier shall provide detailed specification sheets listing all physical, electrical, mechanical, and attenuation characteristics of the finished cable.

4.7 Sample Preparation:

- A minimum of 5 cable samples is required for each test unless otherwise specified. These samples are to be randomly cut from the production lot(s) to be tested. Each sample will be prepared per the requirement of the specific test. Suitable SMA connectors will be utilized to terminate the cable for electrical testing.

4.8 Equipment:

- This list is intended to highlight specialized equipment required to perform the electrical testing specified in this document. Other general purpose lab tools equipment and supplies will also be required.*

Item	Description	Requirements
1	High Voltage Source	800V AC
2	Network Analyzer	6GHz Minimum S Parameter w/Time Domain Capability (see #4)
3	Spark Tester	1750 V Min
4	TDR (Time Domain Reflectometer)	With Impedance capability

TABLE 4.8: Coaxial Cable Test Equipment

*Note: Flame, Abrasion, Immersion, etc. tests listed in this document may contain specific fixture, equipment and tooling requirements. Other general lab equipment such as tensile testers and environmental chambers are to be available for use as required.

5 TEST REQUIREMENTS:

5.1 Electrical Test Requirements:

Test	Reference	Method/procedure	Requirement
Continuity test	MIL – C 17G 3.7.1	MIL – C 17G 4.8.2	Each conductor and shield must be continuous
Spark test	MIL – C 17G 3.7.2	MIL – C 17/119G 4.8.3	No jacket breakdown or flash over @ <2KV rms
Dielectric Withstanding Voltage	MIL – C 17G 3.7.3	MIL – C 17G 4.8.4	No breakdown or flash over @ < 800V rms Inner to outer conductor
Insulation resistance	MIL – C 17G 3.7.4	MIL – C 17G 4.8.5	≥ 10x10 ⁶ MΩ/m
Characteristic impedance	MIL – C 17G 3.7.6	MIL – C 17G 4.8.7	50 +/- 2 Ohms
Rf Insertion loss (attenuation)	MIL – C 17G 3.7.7	MIL – C 17G 4.8.8	Shall not exceed values shown in Figure 3 and Table 3.
Return loss	MIL – C 17G 3.7.8	MIL – C 17G 4.8.9	15.5db min*
Capacitance	MIL – C 17G 3.7.9	MIL – C 17G 4.8.10	31pF/ft nom.
Velocity Of Propagation	MIL- C 17G	MIL- C 17G 6.5.3	64% min.
Shielding Effectiveness (Transfer Impedance)	Transfer impedance method	IEC 1156-1 2.1.1.2	AG174 35 db min AG174LL 60db min
Center conductor resistance		Use a resistance measuring device with an accuracy of ±0.5% and a temperature measurement device with an accuracy of ±0.5° C	8.4 ohms/100 ft. Max. @ 23° C

*VSWR 1.3 max

TABLE 2: Electrical Tests, Methods and Requirements

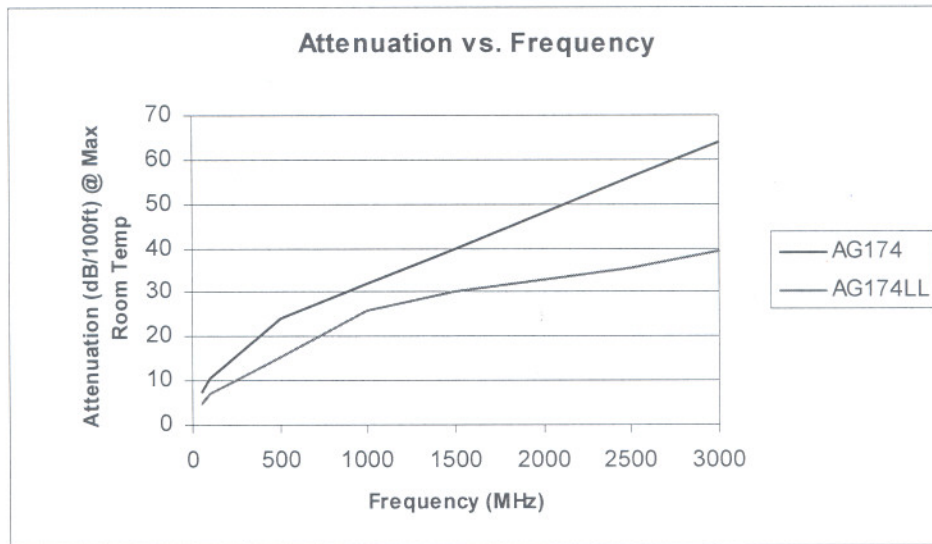

FIGURE 3: Maximum Attenuation Values

Maximum attenuation values for Hz not shown may be may be established by interpolation

Frequency (MHz)	AG174 Attenuation (dB/100ft) Max at room temp	AG174LL Attenuation (dB/100ft) Max at room temp
50	7.5	4.6
100	10.5	7
500	24	15.11
1000	32	25.71
1500	40	30
2500	56	35.4
3000	64	39.4

TABLE 3: Maximum Attenuation

Maximum attenuation values for Hz not shown may be may be established by interpolation.

5.2 Mechanical and Environmental Test Requirements:

Test	Reference	Method/procedure	Requirement
Aging Stability	MIL – C 17G 3.7.15	MIL – C 17G 4.8.16*	No cracks, flaws or other damage of the jacket.
Cold bend	MIL – C 17G 3.7.18	MIL – C 17G 4.8.19*	No cracks, flaws or other damage of the jacket or dielectric core.
Flame propagation	SAE J1128	SAE J 1128 – 6.6	Flame shall self extinguish in $\leq 70s$
Fluid resistance	SAE J1128	J1128	Optional test: see 4.1.3 Maximum change in diameter per SAE J 1128
Abrasion resistance	Sandpaper method	ISO 6722 9.2 ¹ (0.2kg additional mass)	125mm minimum length of sandpaper
Center conductor elongation	ASTM B3	ASTM B3	Annealed copper center conductor only: Conductor shall meet requirements as specified in ASTM B3. Requirements for all other center conductor materials shall be established by agreement between supplier and customer.
Dielectric to center conductor retention	USCAR/EWCAP	See 5.2.1	The center conductor shall withstand a 10N force without pulling out of the dielectric material.
Shield to dielectric retention	USCAR/EWCAP	See: 5.2.2	The Shield shall withstand a 3N force without pulling off of the dielectric.
Jacket to shield retention	USCAR/EWCAP	See 5.2.3	The outer jacket shall withstand a 22N force without pulling off of the shield.
Heat age stability	MIL – C 17G 3.7.15	MIL – C 17G 4.8.16	No cracks, flaws or other damage of the jacket or dielectric core.

¹ For the purpose of this test the resistance to abrasion shall be the minimum length the sandpaper must of travel without exposing the braid or shield.

* Mandrel diameter for various tests shall be 5X finished cable OD.

- 5.2.1 **Fixture:** A suitable plate with a round .0215"/.023" diameter hole (See figure 4) securely mounted in a tensile tester so as to allow the center conductor of the sample specimen to pass through the hole and be attached to the load application device. See figure 5.
Procedure: From a suitable length of cable expose the center conductor by removing 2" (minimum) of jacket, shield and dielectric material. See Figure 6 A. Cut the cable to length so as to leave 1/2" of dielectric material, shield and outer jacket on the end of the specimen. Place the center conductor through the hole in the fixture plate and apply a pull force at a rate of 10 "/minute (250mm/min). A minimum of 5 samples shall be tested.
Acceptance Criteria: See 5.2, Dielectric to center conductor retention.
- 5.2.2 **Fixture:** A suitable plate with a round .0635"/.065" diameter hole (See figure 4) securely mounted in a tensile tester so as to allow the dielectric material to pass through the hole and be attached to the load application device. See figure 5.
Procedure: From a suitable length of cable expose the dielectric by removing 2" (minimum) of outer jacket and 1 1/2"(minimum) of shield material. See figure 6 B. Cut the outer jacket, shield, dielectric and center conductor so as to leave 1/2" of outer jacket material on the end of the specimen. Fold the exposed shield material back over the outer jacket material remaining on the specimen. Place the dielectric through the hole in the fixture plate and apply a pull force at a rate of 10 "/minute (250mm/min). A minimum of 5 samples shall be tested.
Acceptance Criteria: See 5.2, Shield to dielectric retention.
- 5.2.3 **Fixture:** A suitable plate with a .0885"/.090" diameter hole (See figure 4) securely mounted in a tensile tester so as to allow the shield material to pass through the hole and be attached to the load application device. See figure 5.
Procedure: From a suitable length of cable expose the shield by removing 2" (minimum) of outer jacket. See figure 6 C. Cut the cable to length so as to leave 1/2" of outer jacket material on the end of the specimen. Place the shielded portion of the specimen through the hole in the fixture plate and apply a pull force of 10 "/minute (250mm/min). A minimum of 5 samples shall be tested.
Acceptance Criteria: See 5.2, Jacket to shield retention.



FIGURE 4: Typical Test Plate: Hole Size as Specified (Not to Scale)

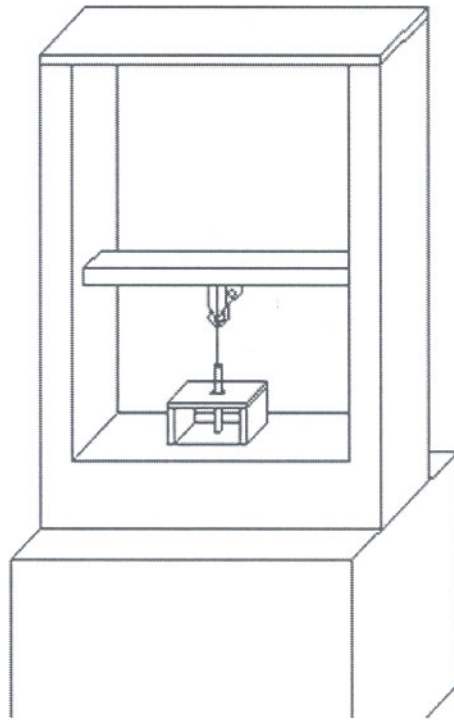

FIGURE 5: Typical Tensile Test Apparatus With Fixture
(Not to Scale)

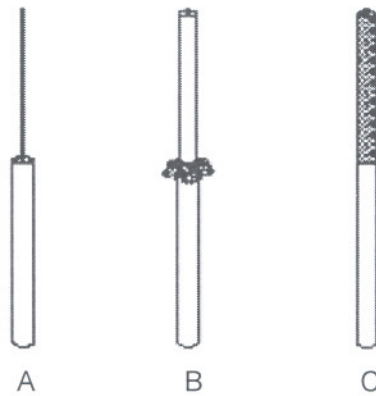

FIGURE 6: Typical Sample Prep
(Not to Scale)

**APPENDIX A
INITIAL CERTIFICATION REQUIREMENTS**

No coaxial cable may be represented as being USCAR/EWCAR compliant unless conformance to all applicable requirements of this specification have been met and are documented. All samples tested must meet these requirements.

CONTINUING CONFORMANCE REQUIREMENTS

4.3	Outer jacketed Diameter
4.3	Shield diameter
4.3	Dielectric Diameter
4.3	Inner conductor diameter
5.1	Characteristic impedance
5.1	Rf Insertion loss (attenuation)
5.1	Return loss

Note: The continuing conformance requirements shall be detailed in the control plan. Documentation requirements shall be established by agreement between supplier and customer.

APPENDIX B
DEFAULT TOLERANCE TABLE
Ref: USCAR 2

Values in this table are applicable only when specific dimensions or tolerances are not specified.

Temperature	$\pm 3^{\circ}\text{C}$
Voltage	$\pm 5\%$
Current	$\pm 5\%$
Resistance	$\pm 5\%$
Length	$\pm 5\%$
Time	$\pm 5\%$
Force	$\pm 5\%$
Frequency	$\pm 5\%$
Flow Rate	$\pm 5\%$
Relative Humidity	$\pm 5\%$
Volume	$\pm 5\%$
Mass	$\pm 5\%$
Mandrel diameter	5X nominal OD

**APPENDIX C
REVISIONS**

This specification was approved by USCAR/EWCAP on 8-1-05

Any revisions since that date have been incorporated into the specification. Revisions that altered the content of the specification are recorded below.

Date	Section	Summary of Changes made	Notes